

## **COPPERHEAD CONDUCTOR SYSTEMS**



## INDEX

	Page		Page
Basic Description, Advantages	2	Railholders and Ground Supports	13
Selection of Conductors and Engineering Data	3	Insulators up to 1000 V	14
Steel Copperhead Rails and Accessories	4-6	High Voltage Insulators	15
Aluminium Copperhead Rails and Accessories	8, 9	Current Collectors	16, 17
Hollow Aluminium Copperhead Rails and Accessories	10	Spare Parts for Current Collectors	18
Fibreglass Copperhead Rails and Accessories	11	Installation Information	19
Solid Copper Rails and Accessories	12	Heating Systems	20, 21
		Questionnaire	22
		Vahle Rails in Action	7, 23
		All Vahle Electrification Systems	back cover

## BASIC DESCRIPTION

The Copperhead Conductor Rail was invented by PAUL VAHLE in the year 1912, and from this beginning the VAHLE COMPANY continuously improved and developed the many Rail Systems, detailed in this catalogue.

The "T" or "hollow T" section and the extruded copperhead is drawn through a special die, which compresses the copper flanges around the dovetail head of the rail, connecting the two components to a 100 % rigid unit.

The well-known VAHLE Copperhead Conductor Rails represent a neat and compact arrangement and have proven an outstanding success for safe power feeding of:

Travelling cranes, Loading bridges, Container handling equipment, Monorails, Hoists, Coking machinery and many other applications.

The VAHLE Copperhead Conductor Rails are available in sizes to meet individual current requirements from 200 to 1,500 Amps.

## SOME ADVANTAGES OF VAHLE RAIL SYSTEMS

With VAHLE-Systems you eliminate all drawbacks inherent in the conventional design of trolley wires, steel angles and steel rails.

Copperhead Rails ensure an efficient and continuous contact.

There is no sparking.

The easy maintenance is a proven low factor.

No losses due to interruption of service, no downtime.

Negligible wear - almost unlimited life of conductors.

Much lower resistance between copperhead and carbon pick-up shoe.

The main users are:

Steel mills, Coking plants, Gas works, Cement industries, Ship yards and Dockside enterprises.

**Fibreglass-Copperhead Rails** are preferably used for applications in corrosive atmospheres and in locations with high humidity.

**Aluminium-Copperhead Rails** are very economical due to the light weight of the Aluminium and its high conductivity.

**Solid-Copper Rails** are recommended for heavy duty current rating and for humid locations.

The rails are supplied in 7 m (23') and 14 m (46') standard lengths, drilled at either end for joint plates or expansion connectors. Shorter lengths are available to coincide with your run way lengths requirements.

We produce a complete range of Accessories, Insulators and Current Collectors.

Low weight of rails and saving of steel superstructure and space.

Variation in temperature and resulting expansion and contraction is compensated by standard expansion joints.

If required, VAHLE Copperhead Rails can also be supplied bent to your specification.

Heating systems are available for all VAHLE Rails.

For Ducting Systems and Housings incorporating VAHLE Rails and Accessories see separate catalogue No. 5 -

Heavy Enclosed Conductor Systems.

## Adequate Ampere Capacity must be provided to carry the anticipated electrical loads:

The total Ampere load is determined from the nominal rated full load current reduced by the duty cycle ( $f_{ED}$ ) and by a diversity factor for non-simultaneous operation.

The average crane motor duty cycle is usually between 40% and 60%, depending on the type of application.

A diversity factor of 0.4 to 0.7 can be used when there are more than one crane on the same runway.

### Example:

3 cranes, each  $I_n = 300$  Amps.

Length of runway: 100 m (330')

Assumed duty cycle: 60% (ED)

Assumed diversity factor: 0.7

Ampere load per crane:  $I_n \times f_{ED} = 300 \text{ A} \times 0.7 = 210 \text{ A}$

Ampere load for 3 cranes:  $210 \text{ A} \times 3 = 630 \text{ A}$

Total Ampere load when using

a diversity factor of 0.7:  $630 \text{ A} \times 0.7 = 441 \text{ A}$

Selected conductors: F 35/100

or: F 45/50

## Formula for Voltage Drop Calculation:

AC:

$$\Delta u = \sqrt{3} \times I \times l \times Z$$

DC:

$$\Delta u = 2 \times I \times l \times R$$

$\Delta u$  = Voltage drop [V]       $R$  = Resistance [Ohm/m]

$I$  = Ampere load [A]       $l$  = Length from power feed to end of conductor [m]

$Z$  = Impedance [Ohm/m]       $L$  = System length [m]

## Engineering data

Conductor Type	Maximum Continuous Amps.	Resistance Ohm/1000 m	Impedance* Ohm/1000 m
L 20/ 14	220	0.506	0.573
L 20/ 25	256	0.386	0.458
L 20/ 50	327	0.251	0.336
L 20/100	444	0.148	0.253
F 35/ 30	320	0.264	0.345
F 35/ 50	410	0.204	0.293
F 35/100	529	0.130	0.238
F 35/150	632	0.096	0.214
F 35/200	724	0.076	0.203
F 45/ 50	495	0.178	0.266
F 45/100	620	0.119	0.223
F 45/150	728	0.089	0.203
F 45/200	826	0.072	0.194
F 45/300	1000	0.051	0.182
F 45/400	1156	0.040	0.174
F 45/500	1299	0.033	0.169
F 45/600	1432	0.028	0.165
A 20/ 14	445	0.183	0.255
A 35/ 30	600	0.101	0.227
A 35/ 50	675	0.091	0.220
A 35/100	795	0.072	0.207

Up to 4000 Amp. Special conductor rails are available.

duty cycle	$f_{ED}$
100 %	1.00
80 %	0.90
60 %	0.78
50 %	0.71
40 %	0.63

## Other Criterion:

a) Select the conductor cross section to carry the calculated total Ampere load and consider the voltage drop calculation to maintain the limits established by the motor manufacturers. The conductor size and/or number of feed points should be increased in case the drop is exceeding the limitations. For very high Ampere loads it may be necessary to provide booster cables.

b) Specify the correct VAHLE-conductor by considering the type of application and environment, such as heavy or light duty service, corrosion, heat, humidity, internal standards.

## Effectice Length:

$l = L$  power feed located at the end of the system

$l = L/2$  power feed located at the mid-point of the system

$l = L/4$  power feed located at both ends of the system

$l = L/6$  power feed located at  $L/6$  from each end of the system

Conductor Type	Maximum Continuous Amps.	Resistance Ohm/1000 m	Impedance* Ohm/1000 m
A 45/ 50	790	0.071	0.201
A 45/100	915	0.060	0.193
A 45/150	1025	0.051	0.188
A 45/200	1110	0.045	0.184
A 45/300	1295	0.036	0.177
A 45/400	1451	0.030	0.172
AC 45/ 60	1000	0.053	0.187
AC 45/110	1080	0.046	0.184
AC 45/150	1160	0.042	0.181
AC 45/200	1225	0.038	0.179
AC 45/300	1370	0.032	0.174
K 45/ 60	220	0.300	0.364
K 45/110	380	0.164	0.248
K 45/150	480	0.120	0.217
K 45/200	575	0.090	0.199
K 45/300	740	0.060	0.182
C 20/200	720	0.088	0.227
C 35/400	1080	0.045	0.197
C 45/500	1210	0.036	0.187
C 45/600	1365	0.031	0.169
C 45/800	1580	0.023	0.168

\* Impedance data based on 150 mm spacing between phases and 50 Hz.  
Current ratings are based on a temperature rise of 30° C over 30° C ambient.



# STEEL-COPPERHEAD RAILS

Scale 1 : 1

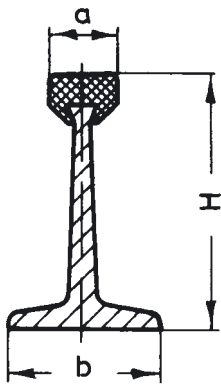

L 20

Type	Copper cross section mm <sup>2</sup>	Steel cross section mm <sup>2</sup>	Equival. total copper conductor mm <sup>2</sup>	H mm	a mm	b mm	Weight kg/m	Max. continuous A	Catalog-No.
L 20/ 14-7	14	150	36	31	6,5	20	1.24	220	100 007
L 20/ 25-7	25	150	47	33	8	20	1.34	256	100 017
L 20/ 50-7	50	150	72	34	10	20	1.57	327	100 027
L 20/100-7	100	150	122	38.5	12	20	2.02	444	100 037

**Standard lengths:**  
7 m (23')

**Main application:**  
conductor system for hoists and monorails, down-shop and cross travel supply for light cranes

**Best applicable collectors: DVD 1 and DVD**

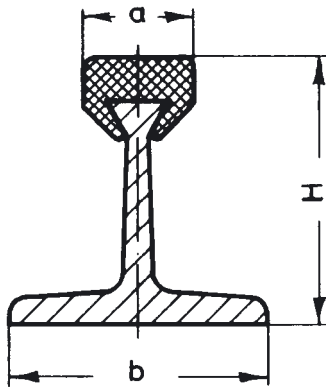

F 35

Type	Copper cross section mm <sup>2</sup>	Steel cross section mm <sup>2</sup>	Equival. total copper conductor mm <sup>2</sup>	H mm	a mm	b mm	Weight kg/m	Max. continuous A	Catalog-No.
F 35/ 30-7	30	265	69	32	14.2	35	2.34	320	104 317
F 35/ 50-7	50	265	89	33.1	14.6	35	2.52	410	100 047
F 35/100-7	100	265	139	36.0	15.3	35	2.97	529	100 057
F 35/150-7	150	265	189	38.3	17.3	35	3.42	632	100 067
F 35/200-7	200	265	239	40.8	17.3	35	3.87	724	100 077

**Standard lengths:**  
7 m (23')

**Main application:**  
conductor system for heavy monorails, down-shop and cross travel supply for medium duty cranes

**Best applicable collectors: GSV 1, GSV 2, GSV 4 and GSV 8**

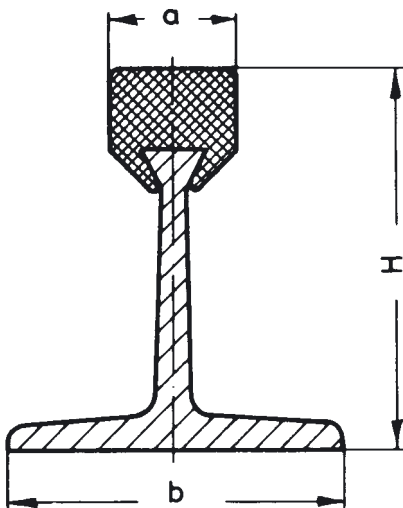

F 45

Type	Copper cross section mm <sup>2</sup>	Steel cross section mm <sup>2</sup>	Equival. total copper conductor mm <sup>2</sup>	H mm	a mm	b mm	Weight kg/m	Max. continuous A	Catalog-No.
F 45/ 50-7	50	355	102	43.1	14.6	45	3.23	495	100 087
F 45/100-7	100	355	152	46.0	15.3	45	3.68	620	100 097
F 45/150-7	150	355	202	48.3	17.3	45	4.13	728	100 107
F 45/200-7	200	355	252	50.8	17.3	45	4.58	826	100 117
F 45/300-7	300	355	352	56.3	17.6	45	5.48	1000	100 127
F 45/400-7	400	355	452	59.3	19.6	45	6.38	1156	100 137
F 45/500-7	500	355	552	64.3	19.6	45	7.28	1299	100 147
F 45/600-7	600	355	652	65.0	23.2	45	8.18	1432	100 157

**Standard lengths:**  
7 m (23')

**Main application:**  
down-shop and cross travel supply for heavy cranes, loading bridges, coking machinery, rapid transit systems etc.

**Best applicable collectors: GSV 1, GSV 2, GSV 4 and GSV 8**

The steel sections can be supplied galvanized or with anticorrosion paint.

Scale 1 : 5

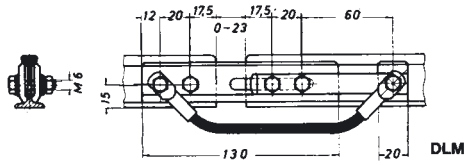

DLM

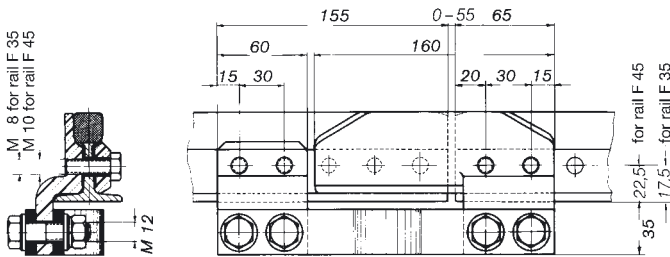

SMDV 35/30-200  
SMDV 45/50-600

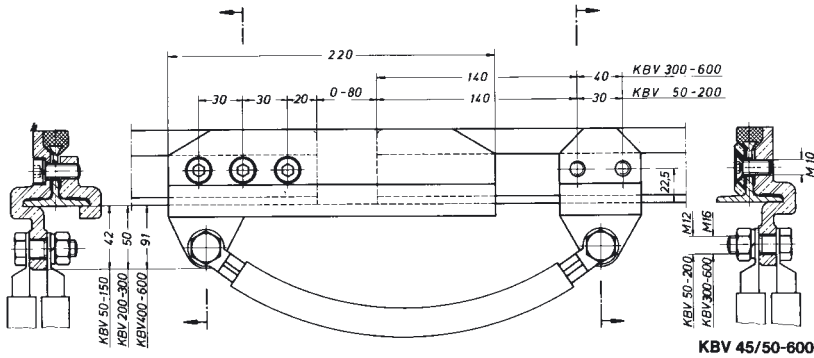

KBV 45/50-600

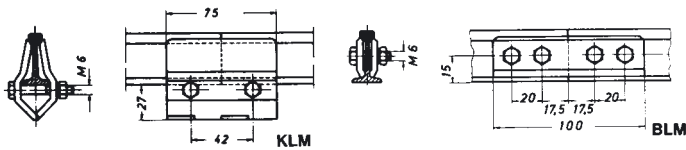

KLM

BLM

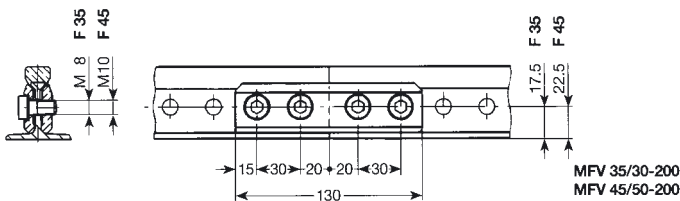

MFV 35/30-200  
MFV 45/50-200

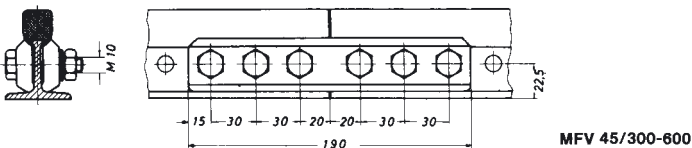

MFV 45/300-600

## Expansion Joints

Type	Material	Weight kg	Catalog-No.
DLM 20/ 14	brass	0.32	100 160
DLM 20/ 25		0.35	100 170
DLM 20/ 50		0.38	100 180
DLM 20/100		0.42	100 190

Type	Material	Weight kg	Catalog-No.
SMDV 35/ 30	brass	1.15	104 340
SMDV 35/ 50		1.15	100 300
SMDV 35/100		1.25	100 310
SMDV 35/150		1.39	100 320
SMDV 35/200		1.48	100 330
SMDV 45/ 50	brass	1.46	100 340
SMDV 45/100		1.56	100 350
SMDV 45/150		1.69	100 360
SMDV 45/200		1.80	100 370
SMDV 45/300		3.06	100 380
SMDV 45/400		3.29	100 390
SMDV 45/500		3.51	100 400
SMDV 45/600	3.78	100 410	

Type	Material	Weight kg	Catalog-No.
KBV 45/ 50	brass	3.61	100 420
KBV 45/100		3.98	100 430
KBV 45/150		4.70	100 440
KBV 45/200		4.90	100 450
KBV 45/300		7.59	100 460
KBV 45/400		7.76	100 470
KBV 45/500		7.94	100 480
KBV 45/600		8.01	100 490

## Rigid Joints

Type	Material	Weight kg	Catalog-No.
KLM 20/ 14-100	brass	0.35	100 500
BLM 20/ 14-100	brass	0.18	100 510
MFV 35/ 30-200	brass	0.41	105 893
MFV 45/ 50-200	brass	0.46	105 897
MFV 45/300-600	brass	1.28	100 540



# ACCESSORIES

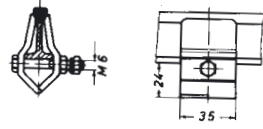

LM 20

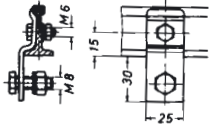

CU 20

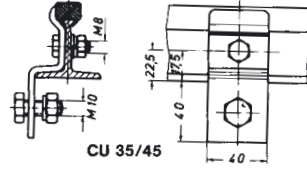

CU 35/45

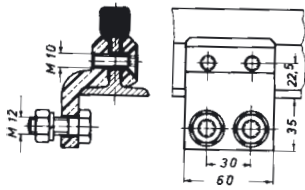

AM 35/45

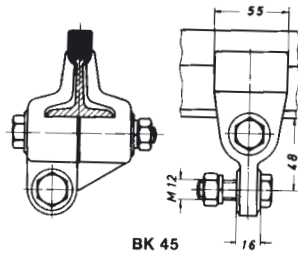

BK 45

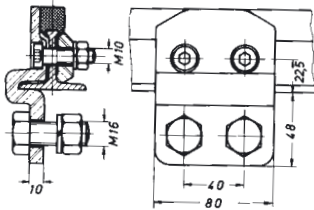

KK 45/300

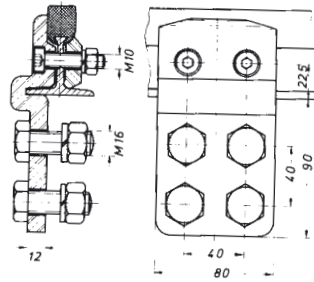

KK 45/400-600

## Feeder Clamps

Type	Material	Weight kg	Catalog-No.
LM 20/ 14-100	brass	0.17	100 590
Cu 20/ 14	copper	0.06	100 600
Cu 20/ 25		0.08	104 840
Cu 20/ 50		0.08	104 850
Cu 20/100		0.09	104 860
Cu 35/ 30	copper	0.16	104 360
Cu 35/ 50		0.17	100 610
Cu 35/100		0.18	100 620
Cu 35/150		0.19	100 630
Cu 35/200		0.20	100 640
Cu 45/ 50	copper	0.20	100 650
Cu 45/100		0.21	100 660
Cu 45/150		0.22	100 670
Cu 45/200		0.22	100 680
AM 35/ 30-200	brass	0.44	105 050
AM 45/ 50-200		0.60	105 080
BK 45/ 50-200	brass	1.29	100 700
BK 45/300-600		1.29	103 460
KK 45/300	brass	1.26	100 710
KK 45/400		1.89	104 760
KK 45/500		1.89	104 770
KK 45/600		1.89	104 780

## Locating clamps

Type	Material	Weight kg	Catalog-No.
LK 20	galvanized	0.04	100 550
SK 35	galvanized	0.11	100 560
SK 45	galvanized	0.12	100 570
SKK 45	polyamid	0.23	100 580

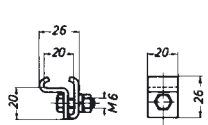

LK 20

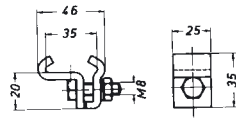

SK 35

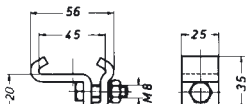

SK 45

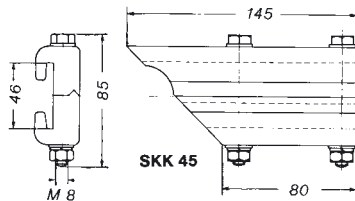

SKK 45





Bridge Crane  
Conductor Transfer Ends



Coking Plant



# ALUMINIUM-COPPERHEAD RAILS

Scale 1 : 1

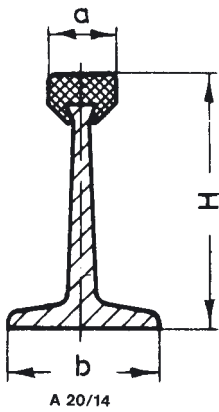

A 20/14

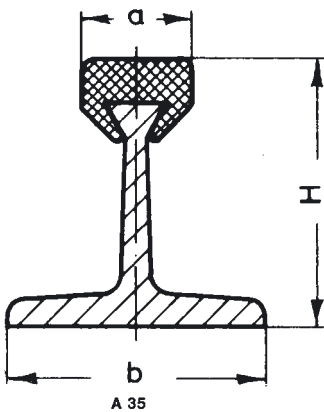

A 35

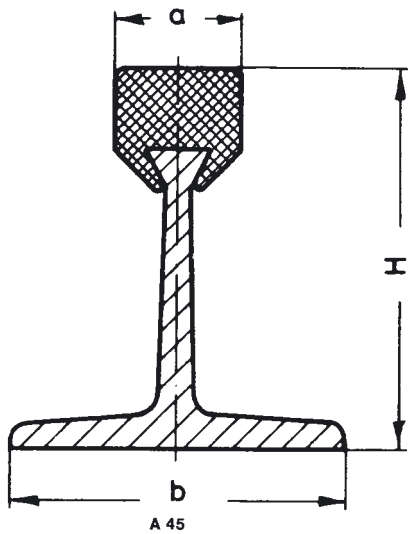

A 45

Type	Copper cross section mm <sup>2</sup>	Aluminium cross section mm <sup>2</sup>	Equival. total copper conductor mm <sup>2</sup>	H mm	a mm	b mm	Weight kg/m	Max. continuous A	Catalog-No.
A 20/14-7	14	150	90	31	6.5	20	0.52	445	103 647

**Standard lengths:**  
7 m (23')

**Main application:**  
conductor system for hoists and monorails, down-shop and cross travel supply for light cranes

**Best applicable collectors: DVD 1 and DVD**

Type	Copper cross section mm <sup>2</sup>	Aluminium cross section mm <sup>2</sup>	Equival. total copper conductor mm <sup>2</sup>	H mm	a mm	b mm	Weight kg/m	Max. continuous A	Catalog-No.
A 35/ 30-7	30	265	160	32	14.2	35	1.00	600	104 327
A 35/ 50-7	50	265	180	33.1	14.6	35	1.18	675	103 657
A 35/100-7	100	265	230	36	15.3	35	1.63	795	103 667

**Standard lengths:**  
7 m (23')

**Main application:**  
conductor system for heavy monorails, down-shop and cross travel supply for medium duty cranes

**Best applicable collectors: GSV 1 and GSV 2**

Type	Copper cross section mm <sup>2</sup>	Aluminium cross section mm <sup>2</sup>	Equival. total copper conductor mm <sup>2</sup>	H mm	a mm	b mm	Weight kg/m	Max. continuous A	Catalog-No.
A 45/ 50-7	50	355	225	43.1	14.6	45	1.42	790	103 677
A 45/100-7	100	355	275	46.0	15.3	45	1.87	915	103 687
A 45/150-7	150	355	325	48.3	17.3	45	2.32	1025	103 697
A 45/200-7	200	355	375	50.8	17.3	45	2.77	1100	103 587
A 45/300-7	300	355	475	56.3	17.6	45	3.67	1295	103 707
A 45/400-7	400	355	575	59.3	19.6	45	4.57	1451	103 717

**Standard lengths:**  
7 m (23')

**Main application:**  
down-shop and cross travel supply for heavy cranes, loading bridges, coking machinery, rapid transit systems etc.

**Best applicable collectors: GSV 1, GSV 2, GSV 4 and GSV 8**

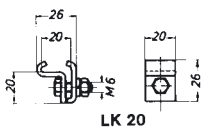

LK 20

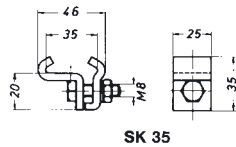

SK 35

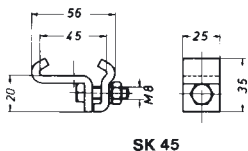

SK 45

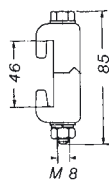

M 8

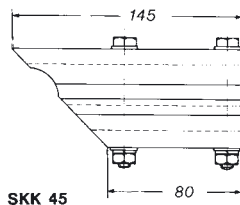

SKK 45

## Locating Clamps

Type	Material	Weight kg	Catalog-No.
LK 20	galvanized	0.04	100 550
SK 35	galvanized	0.11	100 560
SK 45	galvanized	0.12	100 570
SKK 45	polyamid	0.23	100 580





Drawings see page 6

LA 20/14	△	LM 20
AMA 35	△	AM 35/45
KKA 45/ 50-150	△	KK 45/300
KKA 45/200-400	△	KK 45/400-600

Scale 1 : 5

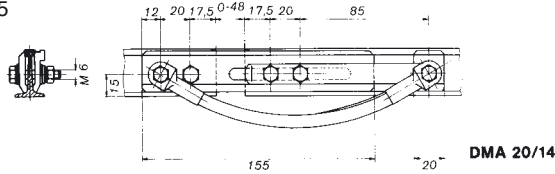

DMA 20/14

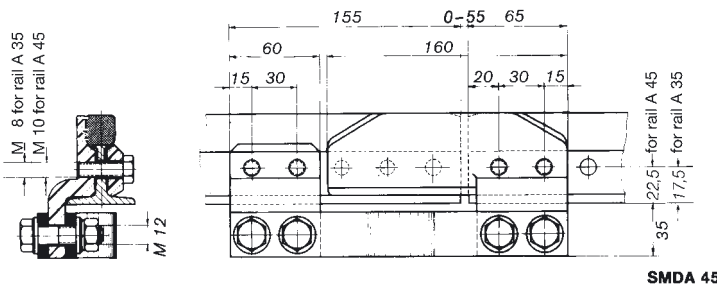

SMDA 45

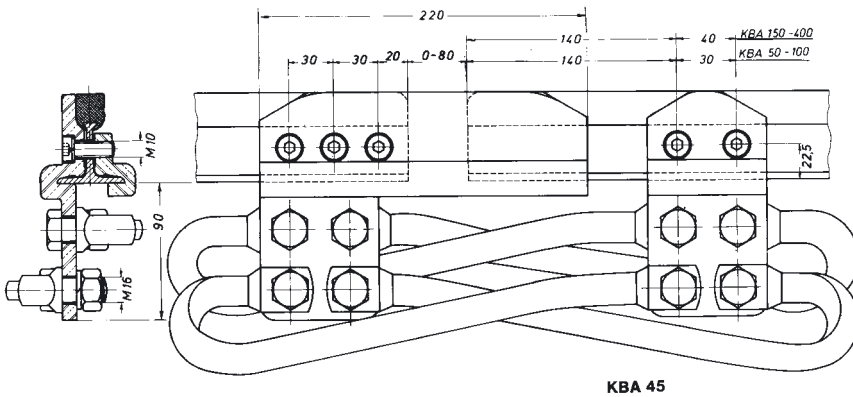

KBA 45

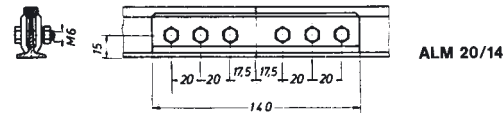

ALM 20/14

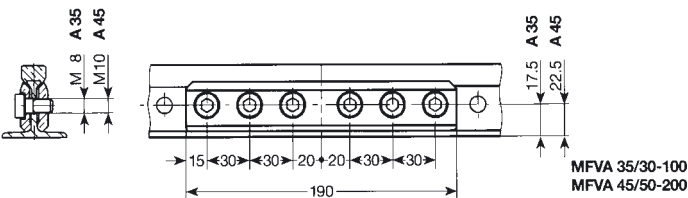

MFVA 35/30-100  
MFVA 45/50-200

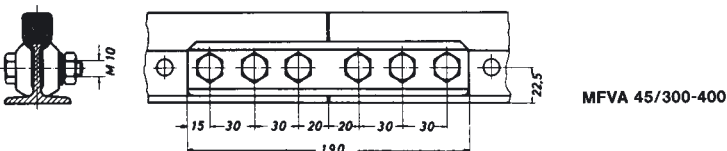

MFVA 45/300-400

## Feeder Clamps

Type	Material	Weight kg	Catalog-No.
LA 20/14	brass	0.14	103 540
AMA 35/ 30	brass	0.44	105 100
AMA 35/ 50		0.44	105 110
AMA 35/100		0.44	105 120
KKA 45/ 50	brass	1.26	104 790
KKA 45/100		1.26	104 800
KKA 45/150		1.89	104 810
KKA 45/200		1.89	105 130
KKA 45/300		1.89	104 820
KKA 45/400		1.89	104 830

## Expansion Joints

Type	Material	Weight kg	Catalog-No.
DMA 20/14	brass	0.43	103 720
SMDA 35/ 30	brass	1.42	104 350
SMDA 35/ 50		1.52	103 780
SMDA 35/100		1.71	103 790
SMDA 45/ 50	brass	1.91	103 800
SMDA 45/100		2.79	103 810
SMDA 45/150		3.18	103 820
SMDA 45/200		6.86	105 679
SMDA 45/300		3.81	103 830
SMDA 45/400		3.87	103 840
KBA 45/ 50		brass	3.86
KBA 45/100	4.00		103 860
KBA 45/150	6.94		103 870
KBA 45/200	6.86		105 680
KBA 45/300	7.93		103 880
KBA 45/400	8.01		103 890

## Rigid Joints

Type	Material	Weight kg	Catalog-No.
ALM 20/14	brass	0.26	101 020
MFVA 35/ 30-100	brass	0.59	105 903
MFVA 45/ 50-200	brass	0.66	105 150
MFVA 45/300-400	brass	1.28	105 160



# HOLLOW-ALUMINIUM-COPPERHEAD RAILS AND ACCESSORIES

Scale 1 : 1

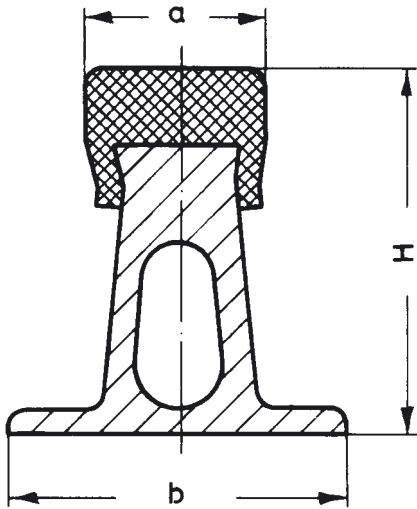

Type	Copper cross section mm <sup>2</sup>	Equival. total copper conductor mm <sup>2</sup>	H mm	a mm	b mm	Weight kg/m	Max. continuous A	Catalog-No.
AC 45/ 60-7	60	360	41	22	45	2.15	1000	100 777
AC 45/110-7	110	410	42	23	45	2.60	1080	100 787
AC 45/150-7	150	450	43	24	45	2.96	1160	100 797
AC 45/200-7	200	500	43	25	45	3.41	1225	100 807
AC 45/300-7	300	600	49	24	45	4.31	1370	100 817

Standard lengths: 7 m (23')

Best applicable collectors: GSV 1, GSV 2, GSV 4 and GSV 8

Scale 1 : 5

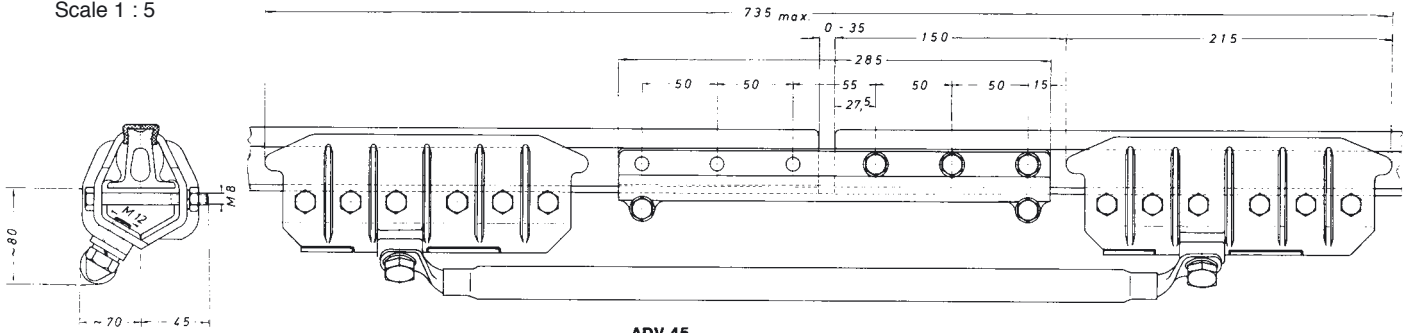

ADV 45

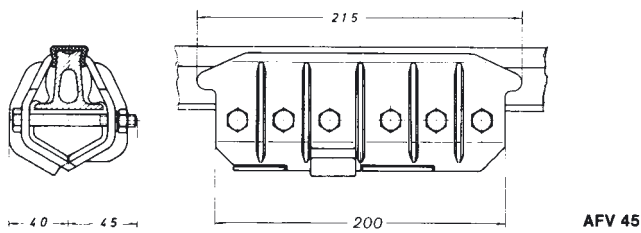

AFV 45

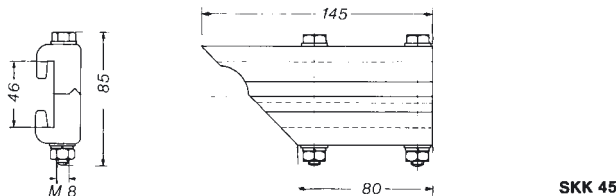

SKK 45

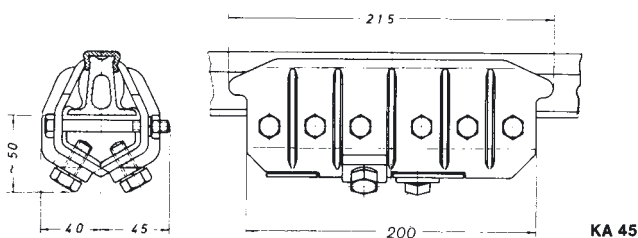

KA 45

Type	Material	Weight kg	Catalog-No.
<b>Expansion Joints</b>			
ADV 45/ 60	brass	7.18	104 680
ADV 45/110		7.18	104 690
ADV 45/150		7.60	104 700
ADV 45/200		7.60	104 710
ADV 45/300		7.60	104 720
<b>Rigid Joints</b>			
AFV 45/ 60	brass	1.98	105 601
AFV 45/110-300		1.90	101 000
<b>Locating Clamps</b>			
SKK 45	polyamid	0.23	100 580
<b>Feeder Clamps</b>			
KA 45/ 60	brass	2.03	105 649
KA 45/110-300		1.95	101 010

# FIBREGLASS-COPPERHEAD RAILS AND ACCESSORIES



Scale 1 : 1

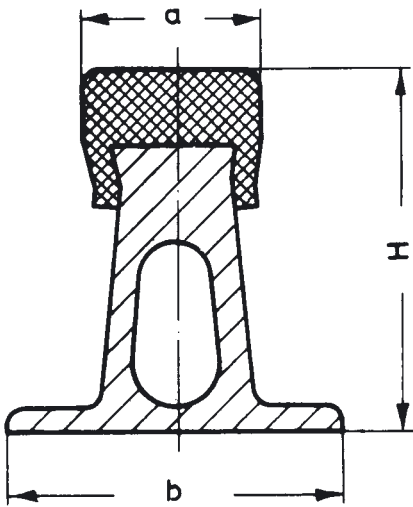

Type	Copper cross section mm <sup>2</sup>	H mm	a mm	b mm	Weight kg/m	Max. continuous A	Catalog-No.
K 45/ 60-7	60	41	22	45	1.61	220	100 727
K 45/110-7	110	42	23	45	2.06	380	100 737
K 45/150-7	150	43	24	45	2.41	480	100 747
K 45/200-7	200	43	25	45	2.86	575	100 757
K 45/300-7	300	49	24	45	3.75	740	100 767

**Standard lengths:**  
7 m (23')

**Main application:**  
down-shop and cross travel supply for medium and heavy duty cranes, loading bridges etc. in locations with very high humidity and very corrosive atmosphere.

**Best applicable collectors:** GSV 1, GSV 2, GSV 4 and GSV 8

Scale 1 : 5

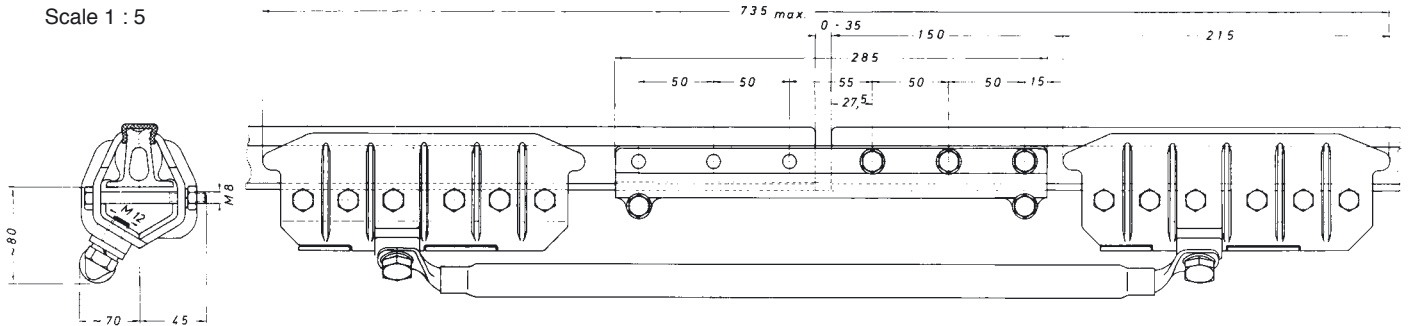

KDV 45

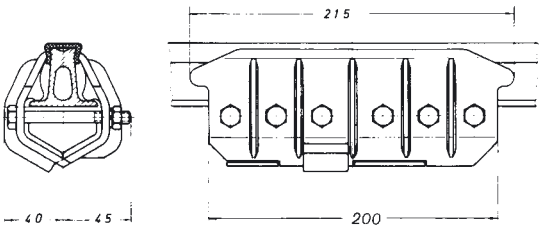

KFV 45

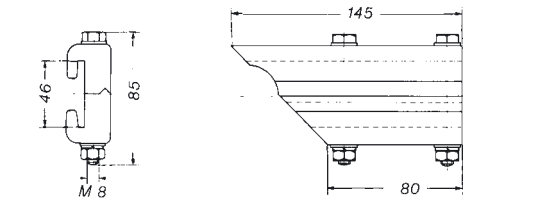

SKK 45

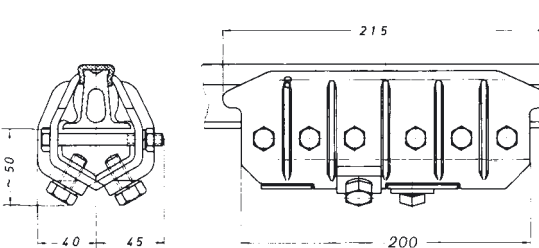

KA 45

Type	Material	Weight kg	Catalog-No.
<b>Expansion Joints</b>			
KDV 45/ 60	brass	5.24	100 860
KDV 45/110		5.41	100 870
KDV 45/150		5.64	100 880
KDV 45/200		5.89	100 890
KDV 45/300		6.11	100 900
<b>Rigid Joints</b>			
KFV 45/ 60	brass	1.98	105 601
KFV 45/110-300		1.90	101 000
<b>Locating Clamps</b>			
SKK 45	polyamid	0.23	100 580
<b>Feeder Clamps</b>			
KA 45/ 60	brass	2.03	105 649
KA 45/110-300		1.95	101 010



# SOLID-COPPER RAILS AND ACCESSORIES

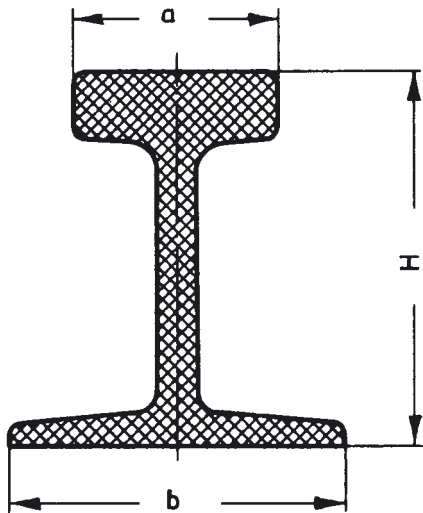

Type	Copper cross section mm <sup>2</sup>	H mm	a mm	b mm	Weight kg/m	Max. continuous A	Catalog-No.
<b>C 20/200-7</b>	200	32	12	20	1.86	720	100 827
<b>C 35/400-7</b>	400	45	12	35	3.55	1080	100 837
<b>C 45/500-7</b>	500	50	16	45	4.45	1210	100 937
<b>C 45/600-7</b>	600	50	25	45	5.32	1365	100 847
<b>C 45/800-7</b>	800	50	27	45	7.12	1580	100 857

**Standard lengths:**  
7 m (23')

**Main application:**

C 20/200 and C 35/400 in conjunction with heavy enclosed conductor systems.

C 45/- series for heavy duty current ratings.

**Best applicable collectors:**

for C 20/200: **DVD, SO and BVS**

for C 35/400, C 45/500, C 45/600, C 45/800: **GSV 1, GSV 2, GSV 4, GSV 8**

Scale 1 : 5

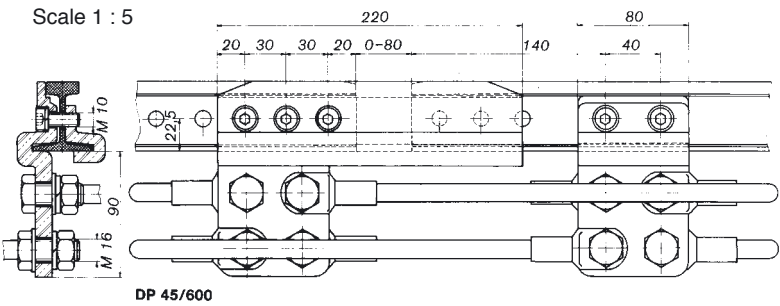

DP 45/600

## Expansion Joints

Type	Material	Weight kg	Catalog-No.
<b>DP 20/200</b>	brass	1.01	100 960
<b>DP 35/400</b>		2.56	100 970
<b>DP 45/500</b>		7.00	100 940
<b>DP 45/600</b>		7.80	100 980
<b>DP 45/800</b>		8.50	100 990

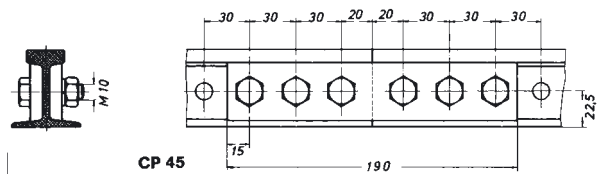

CP 45

## Rigid Joints

Type	Material	Weight kg	Catalog-No.
<b>CP 20/200</b>	copper	0.20	101 100
<b>CP 35/400</b>		0.50	101 110
<b>CP 45/500</b>		1.15	100 950
<b>CP 45/600</b>		1.15	101 120
<b>CP 45/800</b>		1.33	101 130

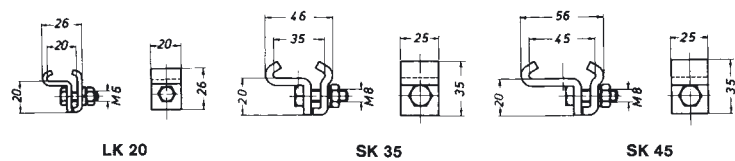

LK 20

SK 35

SK 45

## Locating Clamps

Type	Material	Weight kg	Catalog-No.
<b>LK 20</b>	steel	0.04	100 550
<b>SK 35</b>	steel	0.11	100 560
<b>SK 45</b>	steel	0.12	100 570

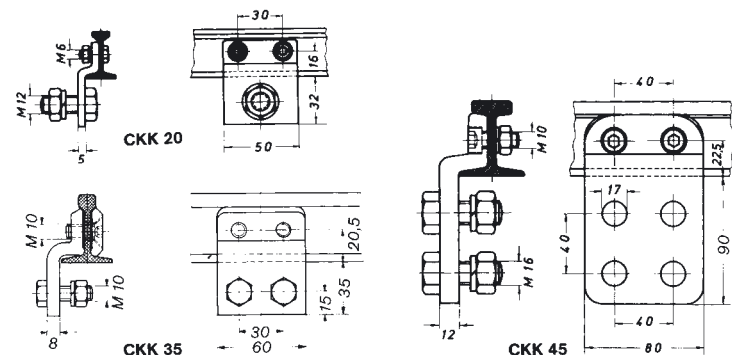

CKK 20

CKK 35

CKK 45

## Feeder Clamps

Type	Material	Weight kg	Catalog-No.
<b>CKK 20/200</b>	copper	0.25	101 140
<b>CKK 35/400</b>	copper	1.50	101 150
<b>CKK 45/500</b>	copper	1.95	101 500
<b>CKK 45/600</b>	brass	1.95	101 160
<b>CKK 45/800</b>	brass	1.95	101 170



Scale 1 : 5

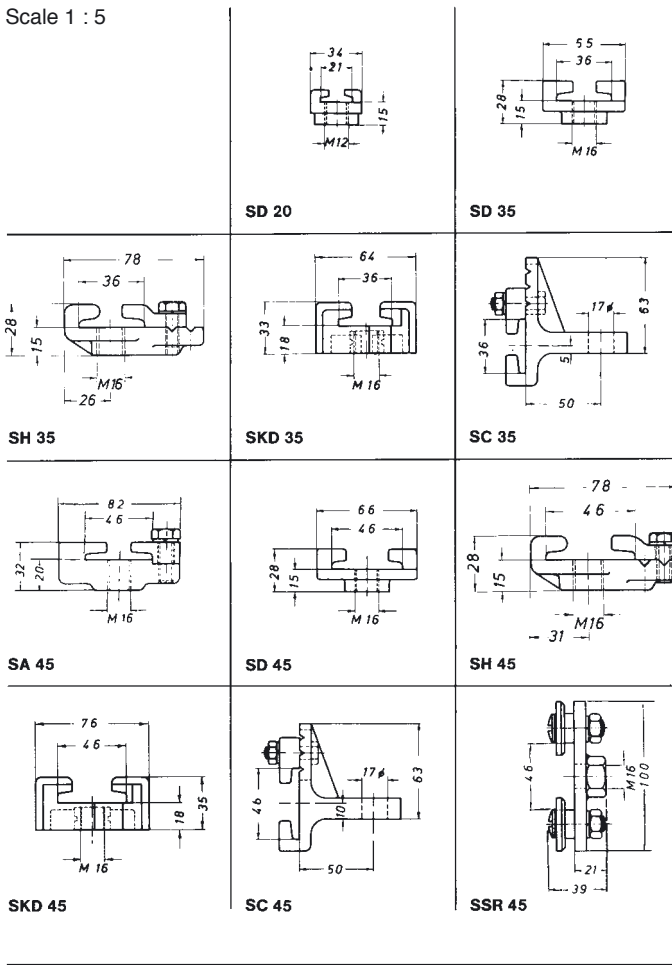

## Rail Holders

Type	Material	Weight kg	Catalog-No.
<b>SD 20</b>	steel	0.15	101 180
<b>SD 35</b>	steel	0.20	101 190
<b>SH 35</b>	steel	0.36	101 200
<b>SKD 35</b>	polyamid	0.05	101 220
<b>SC 35</b>	steel	0.57	101 230
<b>SA 45</b>	aluminium	0.23	104 600
<b>SD 45</b>	steel	0.21	101 240
<b>SH 45</b>	steel	0.36	101 250
<b>SKD 45</b>	polyamid	0.07	101 270
<b>SC 45</b>	steel	0.57	101 280
<b>SSR 45</b>	steel	0.45	104 730

Scale 1 : 5

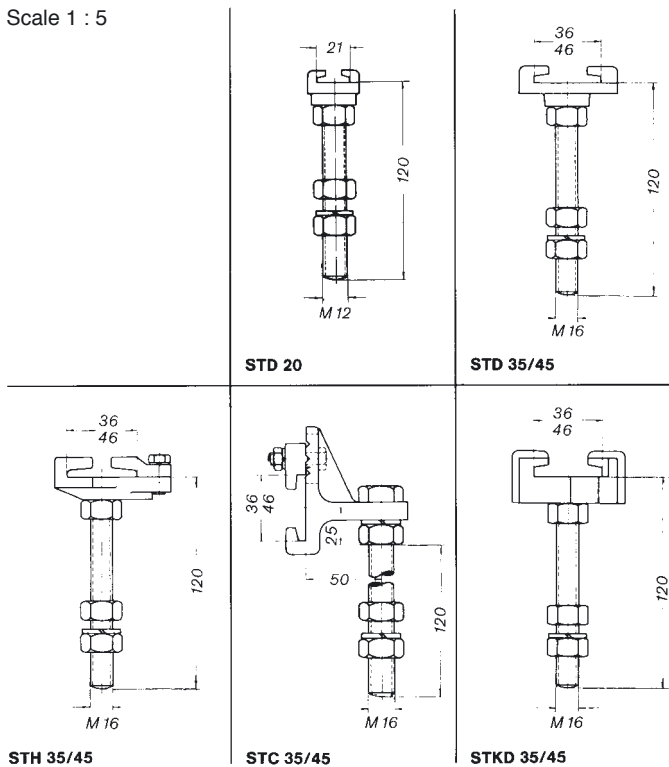

## Rail Supports for Ground

Type	Material	Weight kg	Catalog-No. for bolt lengths 120 mm	Catalog-No. for bolt lengths 180 mm
<b>STD 20</b>	steel	0.26	101 290	—
<b>STD 35</b>	steel	0.47	105 681	101 300
<b>STH 35</b>		0.64	105 682	101 310
<b>STC 35</b>		0.94	105 683	101 320 *
<b>STD 45</b>	steel	0.49	105 684	101 330
<b>STH 45</b>		0.64	105 685	101 340
<b>STC 45</b>		0.94	105 686	101 350 *
<b>STKD 35</b>	polyamid	0.33	105 687	103 380
<b>STKD 45</b>		0.35	105 688	103 390

\* Bolt 150 mm





# INSULATORS

## UP TO 1000 V

Scale 1 : 5

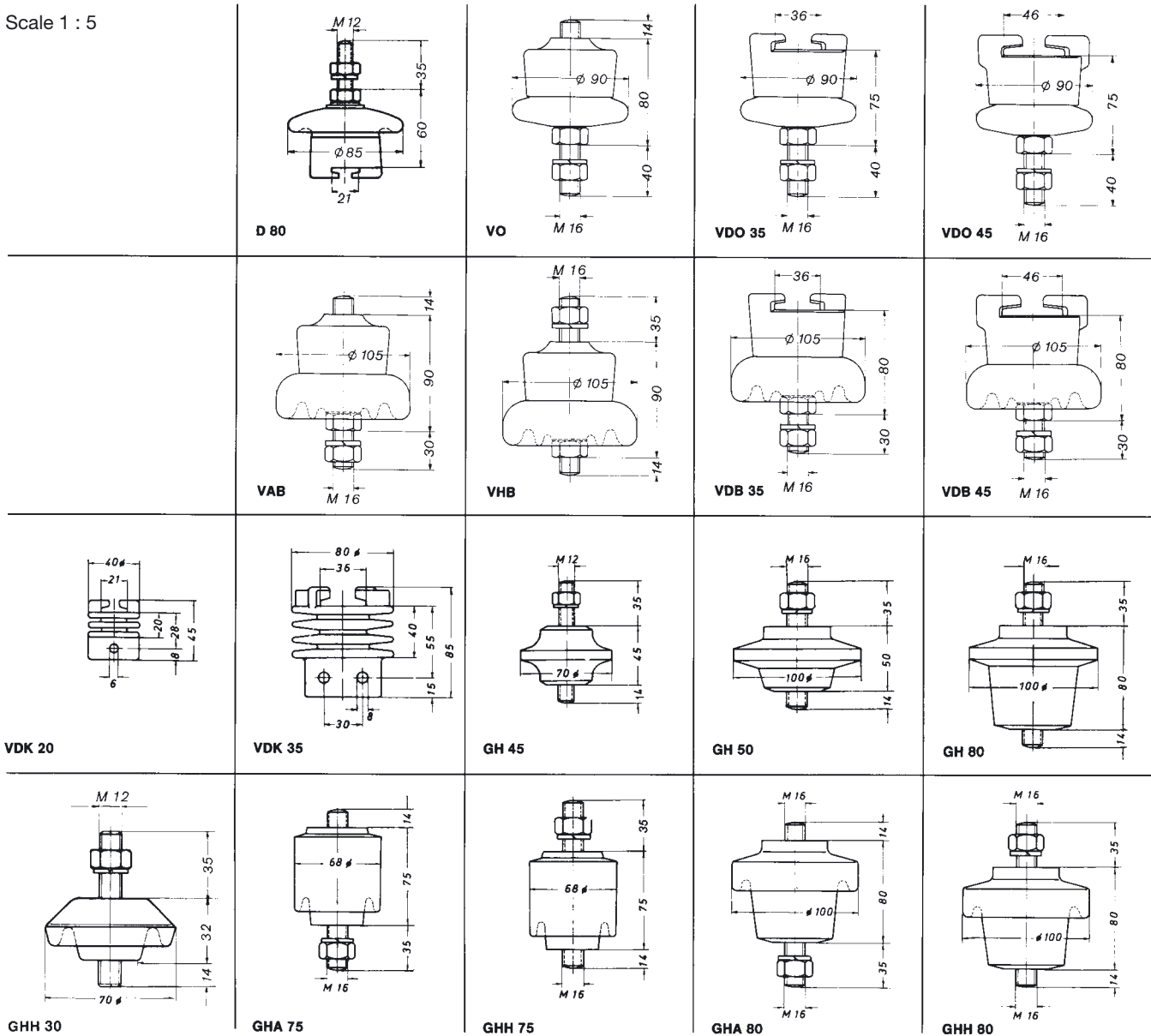

Type	for Rail base	Leakage-Distance mm	Rail Mounting Possibilities	Mechanical Strengths (kp)			Material	Weight kg	Catalog-No. for bolt lengths 30-40 mm		Catalog-No. for bolt lengths 70 mm	
				Tension	Compress.	Cantilever			Phase	Ground	Phase	Ground
D 80	20 mm	60	T →	800	800	450		0.61	white 101 380	brown 101 390		
VO	all rails	60	↓ T →	1800	1800	700	porcelain	1.02	105 667	105 668	white 101 400	brown 101 410
VDO 35	35 mm	60	↓ T →	1800	1800	700		1.20	105 669	105 670	101 580	101 590
VDO 45	45 mm	60	↓ T →	1800	1800	700		1.22	105 671	105 672	101 660	101 670
VAB	all rails	100	↓ T →	2100	2100	770	porcelain	1.51	105 673	105 674	101 440	101 450
VHB	100	100	↓ T →	2100	2100	770		1.51	101 520	101 530	112 900	105 572
VDB 35	35 mm	100	↓ T →	2100	2100	770		1.49	105 675	105 676	101 620	101 630
VDB 45	45 mm	100	↓ T →	2100	2000	770	1.55	105 677	105 678	101 700	101 710	
VDK 20	20 mm	60	↓ T →	300			polyamid	0.04	light 101 780	yellow 101 790		
VDK 35	35 mm	160	↓ T →	600				0.17	101 800	101 810		
GH 45	all rails	70	↓ T →	1600	1500	600	resin	0.26	brown 101 820	yellow 101 830		
GH 50		80	↓ T →	1800	2000	900		0.56	101 840	101 850		
GH 80		120	↓ T →	2100	2000	950		0.82	101 860	101 870		
GHH 30		65	↓ T →	1000	1500	450		0.16	106 090	106 091		
GHA 75		115	↓ T →	1600	2000	650		0.64	101 900	101 910		
GHH 75		115	↓ T →	1600	2000	650		0.64	101 880	101 890		
GHA 80		125	↓ T →	2100	2000	950		0.87	104 650	104 660		
GHH 80		125	↓ T →	2100	2000	950		0.87	104 630	104 640		

# HIGH VOLTAGE INSULATORS



Type	Voltage	Leakage Distance mm	Rail Mounting Possibilities	Mechanical Strengths (kp)			Material	max. Temperatur °C	Weight kg	Catalog-No.	
				Tension	Compress.	Cantilever				Phase	Ground
<b>GH 130</b>	6 kV	210	⊥ T →	5000	7000	2000	resin	90	1.25	brown 104 670	yellow 104 750
<b>VAM</b>	6 kV	220	⊥ →	2500	3000	550	porcelain	140	3.28	white 101 920	brown 101 930
<b>VHM</b>	6 kV	220	T →	2500	3000	550				101 940	101 950
<b>VAK</b>	20 kV	400	⊥ →	2000	2500	500	porcelain	140	7.09	brown 102 000	brown 102 000
<b>VHK</b>	20 kV	400	T →	2000	2500	500				102 020	102 020

Scale 1 : 5

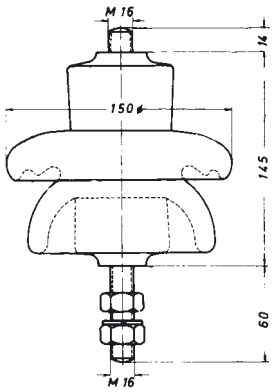

VAM

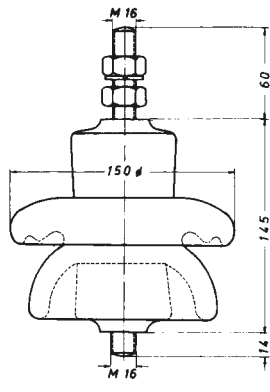

VHM

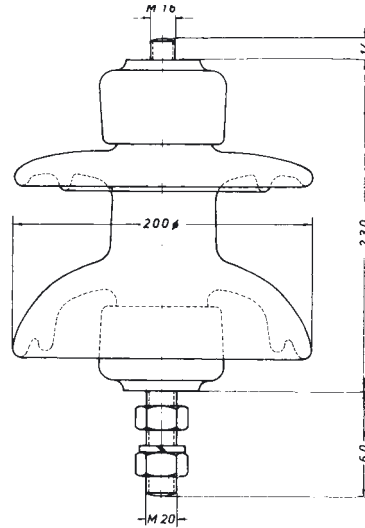

VAK

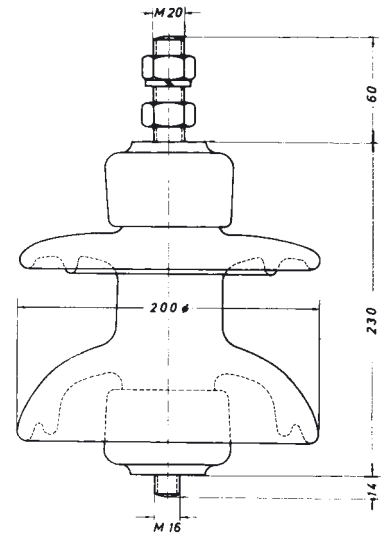

VHK

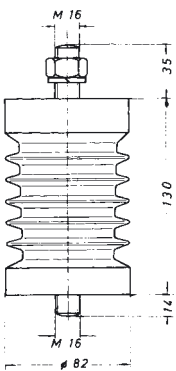

GH 130



# HEAVY DUTY CURRENT COLLECTORS

Scale 1 : 10

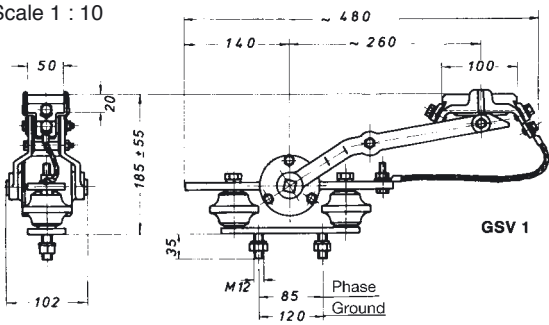

Type	Capacity A	Pick-up Shoes		Weight kg	Catalog-No.		
		Material	Dimensions mm		Phase	Ground	
					insul.	uninsul.	
<b>GSV 1</b>	100	graphite carbon	50 x 100 x 20	5.20	102 080	102 090	103 920
<b>GSV 1/mi</b>	100	met.-impr. carbon	50 x 100 x 20	5.33	102 100	102 110	103 930
<b>GSV 1/S</b>	100	graphite carbon	80 x 100 x 30	5.82	102 120	102 130	103 940
<b>GSV 1/Smi</b>	100	met.-impr. carbon	80 x 100 x 30	6.01	102 140	102 150	103 950
<b>GSV 1/Ms</b>	100	brass	60 x 100 x 12	5.52	102 160	102 170	103 960

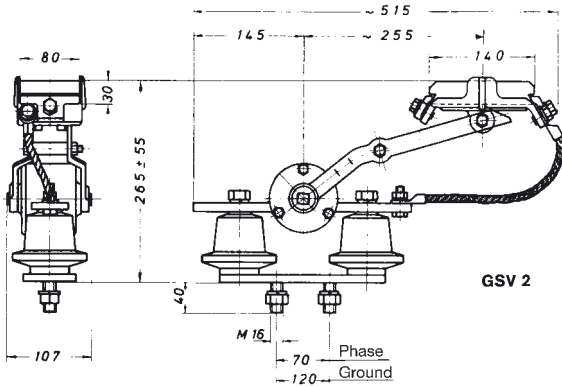

Type	Capacity A	Pick-up Shoes		Weight kg	Catalog-No.		
		Material	Dimensions mm		Phase	Ground	
					insul.	uninsul.	
<b>GSV 2</b>	200	graphite carbon	80 x 140 x 30	9.30	102 200	102 210	103 980
<b>GSV 2/mi</b>	200	met.-impr. carbon	80 x 140 x 30	9.55	102 220	102 230	103 990
<b>GSV 2/Nmi</b>	200	met.-impr. carbon	80 x 140 x 30	8.86	102 240	102 250	104 000
<b>GSV 2/Ms</b>	200	brass	90 x 125 x 15	9.56	102 260	102 270	104 010
<b>GSV 2/GG</b>	200	cast iron	90 x 140 x 15	9.22	102 280	102 290	104 300

height of GSV 2/N : 235±55

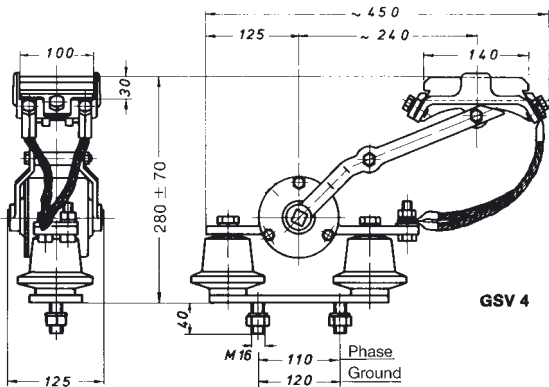

Type	Capacity A	Pick-up Shoes		Weight kg	Catalog-No.		
		Material	Dimensions mm		Phase	Ground	
					insul.	uninsul.	
<b>GSV 4</b>	400	graphite carbon	100 x 140 x 30	11.72	102 300	102 310	104 020
<b>GSV 4/mi</b>	400	met.-impr. carbon	100 x 140 x 30	12.10	102 320	102 330	104 030
<b>GSV 4/Nmi</b>	400	met.-impr. carbon	100 x 140 x 30	11.58	102 340	102 350	104 070
<b>GSV 4/Smi</b>	400	met.-impr. carbon	140 x 140 x 30	13.16	104 040	104 050	104 060
<b>GSV 4/Ms</b>	400	brass	90 x 125 x 15	11.57	102 360	102 370	104 080

height of GSV 4/N : 250±70

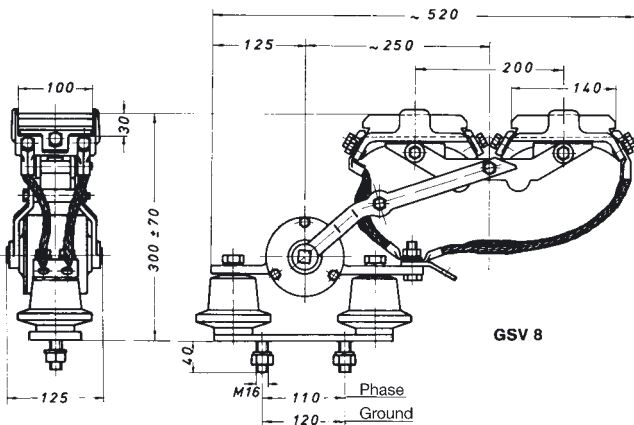

Type	Capacity A	Pick-up Shoes		Weight kg	Catalog-No.		
		Material	Dimensions mm		Phase	Ground	
					insul.	uninsul.	
<b>GSV 8</b>	800	graphite carbon	100 x 140 x 30	15.34	102 380	102 390	104 090
<b>GSV 8/mi</b>	800	met.-impr. carbon	100 x 140 x 30	15.79	102 400	102 410	104 100
<b>GSV 8/Nmi</b>	800	met.-impr. carbon	100 x 140 x 30	15.43	102 420	102 430	104 140
<b>GSV 8/Smi</b>	800	met.-impr. carbon	140 x 140 x 30	18.16	104 110	104 120	104 130
<b>GSV 8/Ms</b>	800	brass	90 x 125 x 15	15.05	102 440	102 450	104 150

height of GSV 8/N : 270 ±70

All malleable iron parts are galvanized. They can be plastic-coated for a small surcharge.  
Insulators are high quality cast resin.

Scale 1 : 10

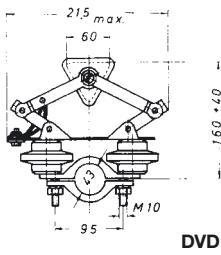

**DVD**

## Type DVD for medium duty

Type	Capacity A	Pick-up Shoes		Width mm	Weight kg	Catalog-No.		
		Material	Dimensions mm			Phase	Ground insul. uninsul.	
<b>DVD</b>	100	graphite carbon	Δ 60 x 65	105	2.56	102 480	102 490	104170

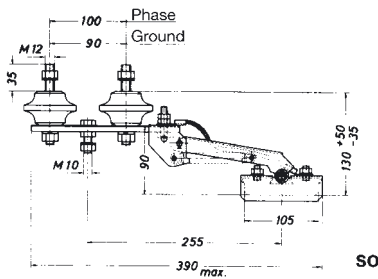

**SO**

## Type SO for enclosed Conductors (FK System)

Type	Capacity A	Pick-up Shoes		Width mm	Weight kg	Catalog-No.	
		Material	Dimensions mm			Phase	Ground
<b>SO</b>	120	metal- impr. carbon	105 x 36 x 25	50	1.56	102 540	102 550

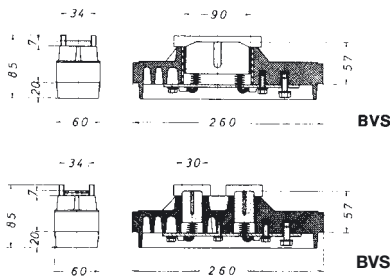

**BVS**

**BVS for Ground**

## Type BVS for enclosed Conductors (CP System)

Type	Capacity A	Pick-up Shoes		Width mm	Weight kg	Catalog-No.	
		Material	Dimensions mm			Phase	Ground
<b>BVS/1</b>	120	metal- impr. carbon	90 x 34 x 42	60	1.40	102 560	—
<b>BVS/1</b>	120	metal- impr. carbon	30 x 34 x 42	60	1.30	—	102 570
<b>BVS/2</b>	180	high dens. carbon	90 x 34 x 42	60	1.96	105 891	—
<b>BVS/2</b>	180	high dens. carbon	30 x 34 x 43	60	1.80	—	105 892

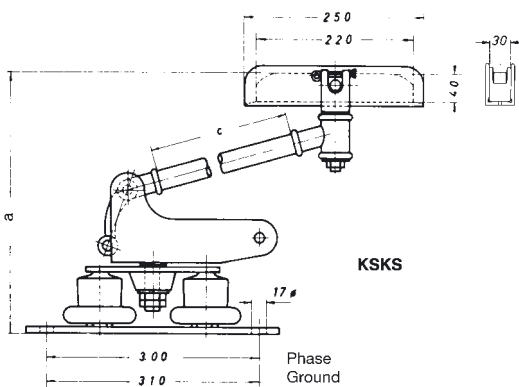

**KSKS**

## Type KSKS for Coking Plants\*

Type	Capacity A	Pick-up Shoes		Width mm	Weight kg	Catalog-No.	
		Material	Dimensions mm			Phase	Ground
<b>KSKS 2/ 600</b>	200	1 metal- impr. carbon	30 x 220 x 40	105	17.01	105 170	105 320
<b>KSKS 2/ 800</b>					17.55	105 180	105 330
<b>KSKS 2/1000</b>					18.24	105 190	105 340
<b>KSKS 4/ 600</b>	400	2 metal- impr. carbons	2 x 30 x 220 x 40	105	22.53	102 510	102 530
<b>KSKS 4/ 800</b>					23.12	105 590	105 594
<b>KSKS 4/1000</b>					23.85	105 591	105 595

The following KS collector heights "a" will result from the different contact arm dimensions "c":

Dimensions c	Dimensions a		
	min.	normal	max.
600	340	650	950
800	340	750	1150
1000	340	850	1350

\* Don't use on less than 150 sq. mm copperhead rails.



# SPARE PARTS FOR CURRENT COLLECTORS

Description	Part. No.	GSV 1 Catalog-No.	GSV 1 S Catalog-No.	GSV 2 Catalog-No.
collector spring	1	102 640	102 640	102 800
spring bolt	2	102 650	102 650	102 810
lever w/thread, mod. 616	3	104 490	104 490	102 660
lever w/boring, mod. 615	4	104 500	104 500	102 670
insulator w/o bolts	5	102 680	102 680	102 820
phase ground		105 380	105 380	105 492
insulator for N-series		-	-	102 830
w/o bolts		-	-	105 491
spacer tubes, 1 set	6	102 690	102 690	102 840
copper shunt lead, 1 set	7	102 710	102 710	102 860
carbon brush, graphite	8	102 720	102 770	102 870
carbon brush, metal-impr.		102 730	102 780	102 880
carbon holder w/clamps	9	102 740	102 790	102 890
pick-up shoe, (brass)	10	102 750	-	102 900
pick-up shoe, (GG-20)	11	102 760	-	102 910

Description	Part. No.	GSV 4 Catalog-No.	GSV 8 Catalog-No.
collector spring	1	102 920	103 010
spring bolt	2	102 930	102 930
lever w/thread, mod. 616	3	102 660	102 660
lever w/boring, mod. 615	4	102 670	102 670
insulator w/o bolts	5	102 820	102 820
phase ground		105 492	105 492
insulator for N-series		102 830	102 830
w/o bolts		105 491	105 491
spacer tubes, 1 set	6	102 940	103 020
copper shunt lead, 1 set	7	102 960	103 040
carbon brush, graphite	8	102 970	102 970
carbon brush, metal-impr.		102 980	102 980
carbon brush, metal-impr. (140 x 140 x 30)		104 190	104 190
carbon holder w/clamps	9	102 990	102 990
carbon holder w/clamps (140 x 140 x 30)		104 200	104 200
pick-up shoe (brass)	10	103 000	103 000
swing, 1 set	12	-	103 050

Description	Part. No.	DVD Catalog-No.
base plate	1	103 190
bow	2	103 200
lever	3	103 210
lever	5	105 690
clip,	6	106 019
phase ground		106 020
copper shunt lead, 1 set	8	103 250
tension spring	9	103 260
spacer tube	10	103 270
insulator	11	103 150
phase ground		105 370
triangular carbon, graphite	12	103 280
triangular side plate	13	103 180

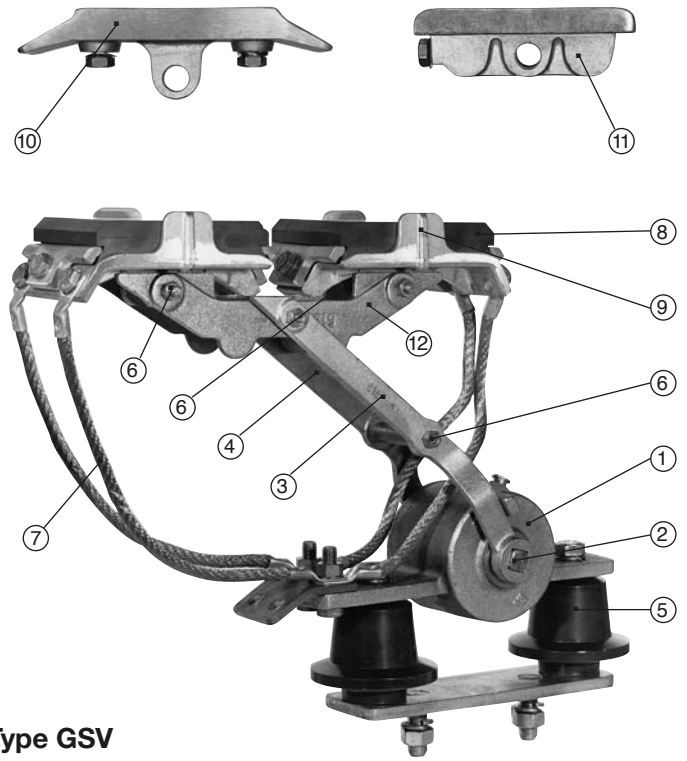

Type GSV

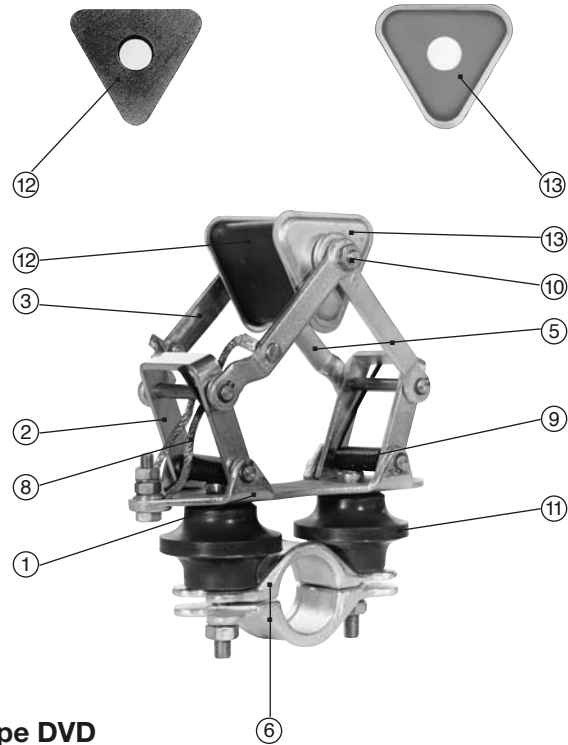

Type DVD



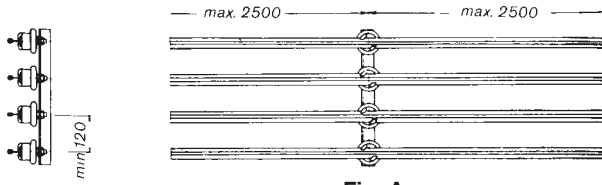
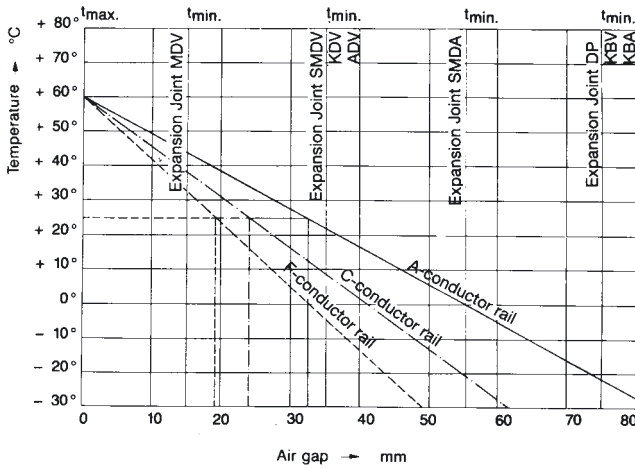

Fig. A

Expansion diagram



## Expansion diagram

The chart shows orientation lines for the different conductor rails, considering 42 m expansion joint intervals.

For gap setting move the orientation line in parallel up to the point presenting the anticipated max. ambient temperature.

Then connect point of actual ambient temperature during installation to the right until intersecting with the orientation line. Follow the vertical axis downward to read the air gap dimension in mm.

### Example:

Ambient temperature 25° C

Air gap F-Rail = 19 mm

Air gap C-Rail = 24 mm

Air gap A-Rail = 33 mm

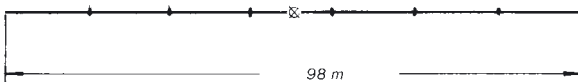

Fig. B



Fig. C

### Symbols:

- I Rigid Joint
- II Expansion Joint
- O Insulator
- ⊗ Insulator with Locating Clamps

## 1.

Install brackets to I beam or girder, weld or bolt on 2 m (6' - 6'') centers for L 20, A 20, C 20 Rails; 2.5 m (8' - 3'') centers for all other rails.

Spacing between VAHLE Rails is 150 mm std. (6''), min. 100 mm (4'') for L 20, A 20, C 20 Rails; 150 mm std. (6''), min. 120 mm (5'') for all other Types.

For high voltage installations: approx. 250 mm (10'')  
Check alignment.

## 2.

Secure insulators/rail supports to brackets (in accordance with the mounting instructions – see pages 13–15) leaving bolts **hand tight**.  
For general Arrangement see Fig. A.

When placing the conductors into the insulators, make sure that the **bayonet clamp** (incorporated in most VAHLE insulators) supports the rail **sliding tight** to allow for expansion and contraction.

Do not change the position (don't turn rail holders) when tightening support bolts against steel brackets.

## 3.

Connect the VAHLE Rails by rigid- or expansion joints using the holes provided at the ends of the 7 m (23') sections. For systems up to 100 m (330') no expansion joints required. With longer runs use an expansion joint after every 6 standard lengths of 7 m (23') intervals. For special heat environment and strong temperature fluctuations reduce these intervals to 28 m (92'). For gap setting see adjacent diagram and example.

Provide an extra insulator/Rail support close to each expansion joint – approx. 250 mm.

## 4.

Anchor VAHLE Rails for **controlled sliding** in both directions, by fitting two locating clamps close to the center insulator of the run or in the center between two expansion joints (see Fig. B + C).

## 5.

Install feeder clamps at feed points. Bolt to web of rail and braise to copperhead.

## 6.

Prepare Collector Bracket to suite normal working height and fixing studs of Current Collectors (See page 16 and 17) and install Collectors securely.



# HEATING SYSTEMS FOR ICING CONDITIONS

## Selection of heating cable:

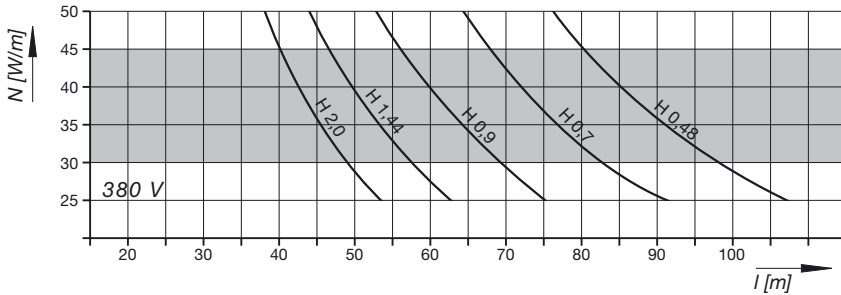
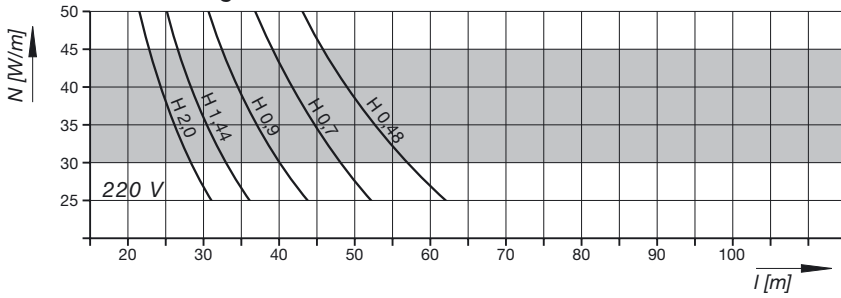

**Composition of heating cable:** Conductor: resistor material CrNi, stranded  
 Insulation: TFE-(Teflon)-insulation, natural colour, glass silk sheath  
 Sheath: V2A wire

Determine a heating cable of 30 to 45 W/m capacity.

If no suitable result from adjacent diagrams, divide the length of the system into two or more heating sections.

Supply lower voltage via a transformer in case of shorter heating sections.

$$\text{Heating capacity [Watt/m]} : N' = \frac{U^2}{R \cdot L^2}$$

$U$  = Supply voltage [Volt]  
 $R$  = Resistance of heating cable [Ohm/m]  
 $L$  = Length of heating sections [m]

### Wire Resistance data:

heating cable: H 0.48 → 0.48 Ohm/m  
 heating cable: H 0.70 → 0.70 Ohm/m  
 heating cable: H 0.90 → 1.00 Ohm/m  
 heating cable: H 1.44 → 1.44 Ohm/m  
 heating cable: H 2.00 → 2.00 Ohm/m

Tolerance: ± 2.5%  
 Outside diameter: ca. 4 mm

## Scheme of heating system for one section

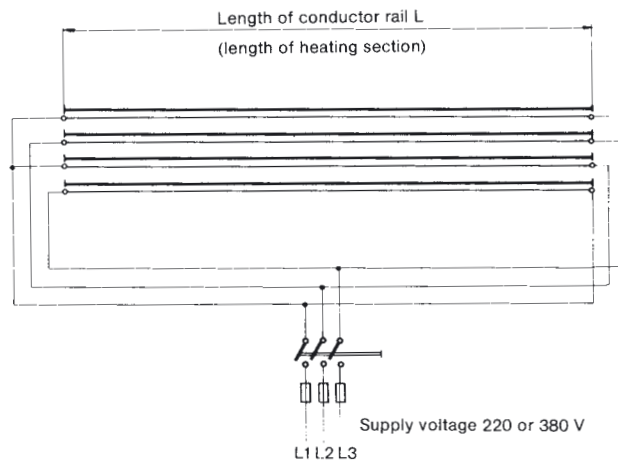

## Symbols:

- Conductor rail
- Heating cable with terminal clamp
- Connection of insulated conductor cable NSYAF 2.5 mm<sup>2</sup>

## Scheme of heating system for more than one section

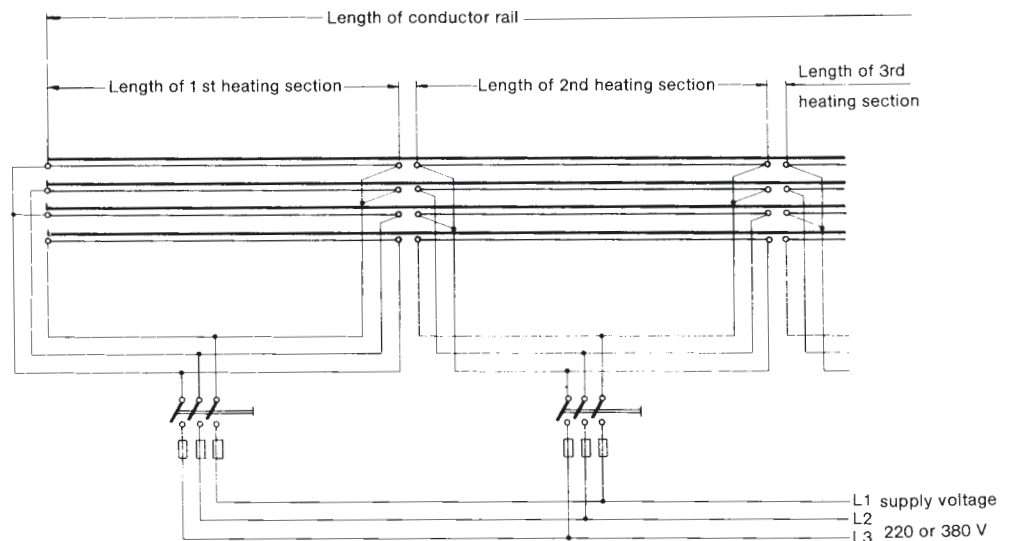

## Heating system for steel and aluminium copper head rails:

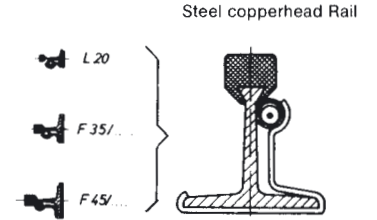
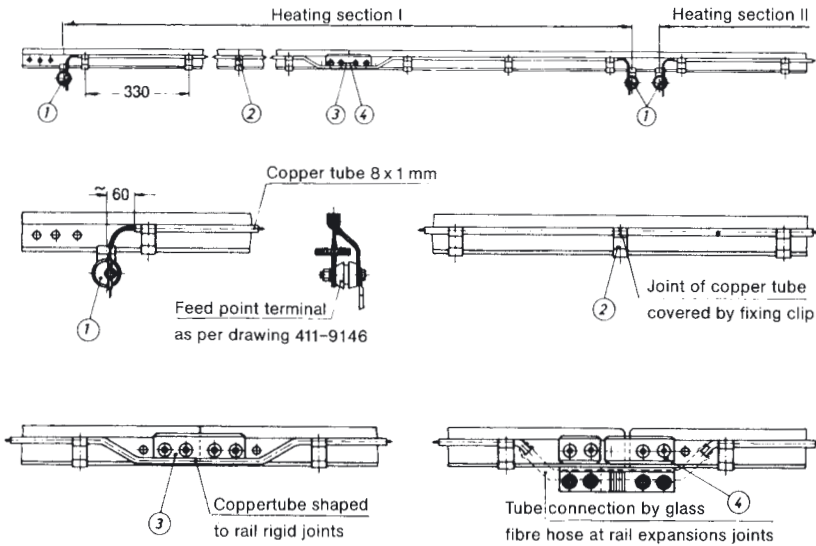

### Our supply includes:

- Heating cable of adequate size
- Copper protection tube
- Fixing clips
- Glass fibre hose for expansion joints
- Insulated terminal clamps
- Material for end connections (cable lugs etc.)
- Mounting instructions
- All switches, fuses, cable etc. by others!

The heating cable is protected by a copper tube.  
 The fixing, easily arranged by galvanized steel clips.  
 Rigid and expansion joints are bridged as above sketches.  
 The ends of heating cable are connected by insulated terminal clamps.

## Heating system for fibre glass and aluminium copper head rails:

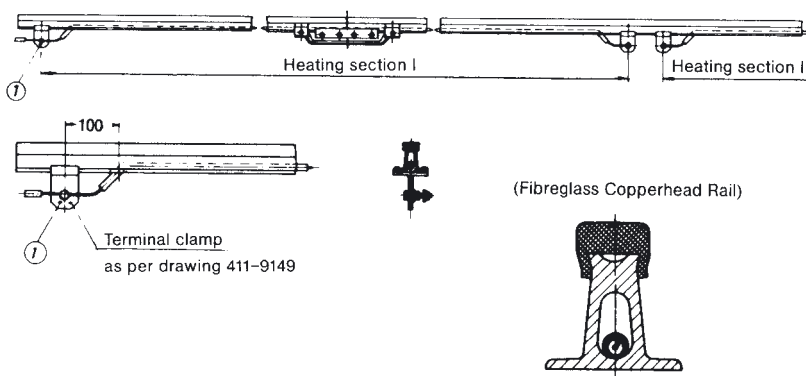

### Scheme for automatic thermostat operation

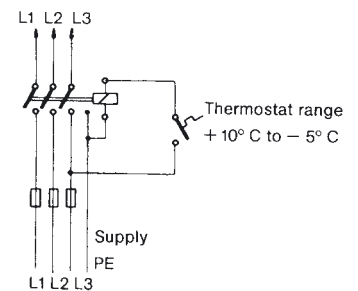

### Our supply includes:

- Heating cable of adequate type
- Feeder terminals
- Material for end connections (cable lugs etc.)
- Mounting instructions
- All switches, fuses, cable etc. by others.

The heating cable is installed in the hollow web of the VAHLE rails, holes for feed cable drilled at terminal-feed points.



# QUESTIONNAIRE FOR VAHLE CONDUCTOR SYSTEMS

To our nearest local agency:

Address: \_\_\_\_\_

Attention of: \_\_\_\_\_

Date: \_\_\_\_\_

1. Type of crane/machine to be electrified: \_\_\_\_\_
2. Voltage: \_\_\_\_\_ Volts ~/=: \_\_\_\_\_ Phases: \_\_\_\_\_ c/s: \_\_\_\_\_
3. Length of conductor system: \_\_\_\_\_
4. Number of conductors required: \_\_\_\_\_ power lines: \_\_\_\_\_ control lines: \_\_\_\_\_ neutral (ground): \_\_\_\_\_
5. Indoor:  Outdoor:
6. Special site conditions (humidity, dust, chemical influence etc.): \_\_\_\_\_
7. Temperature conditions: \_\_\_\_\_ °C min., \_\_\_\_\_ °C max.
8. Type of conductors preferably wanted: \_\_\_\_\_
9. Number and position of feeder points: \_\_\_\_\_
10. Mounting position envisaged: \_\_\_\_\_  
(prints and sketches should be submitted whenever obtainable)
11. Number of cranes / machines fed from the one system: \_\_\_\_\_
12. Ampere load of each crane / machine: \_\_\_\_\_
13. Other pertinent data: \_\_\_\_\_

For curved tracks, breaks in system etc. please submit prints and sketches.

## Motor data Questionnaire Ref. 12 (to determine conductor size)

	Crane 1			Crane 2			Crane 3		
	HP / kW	Current A	% ED	HP / kW	Current A	% ED	HP / kW	Current A	% ED
Motor Gen. Set.									
Main Hoisting									
Aux. Hoisting									
Main Traverse									
Aux. Traverse									
Main Travel									
Aux. Travel									
Slewing									
Luffing and any other Service									



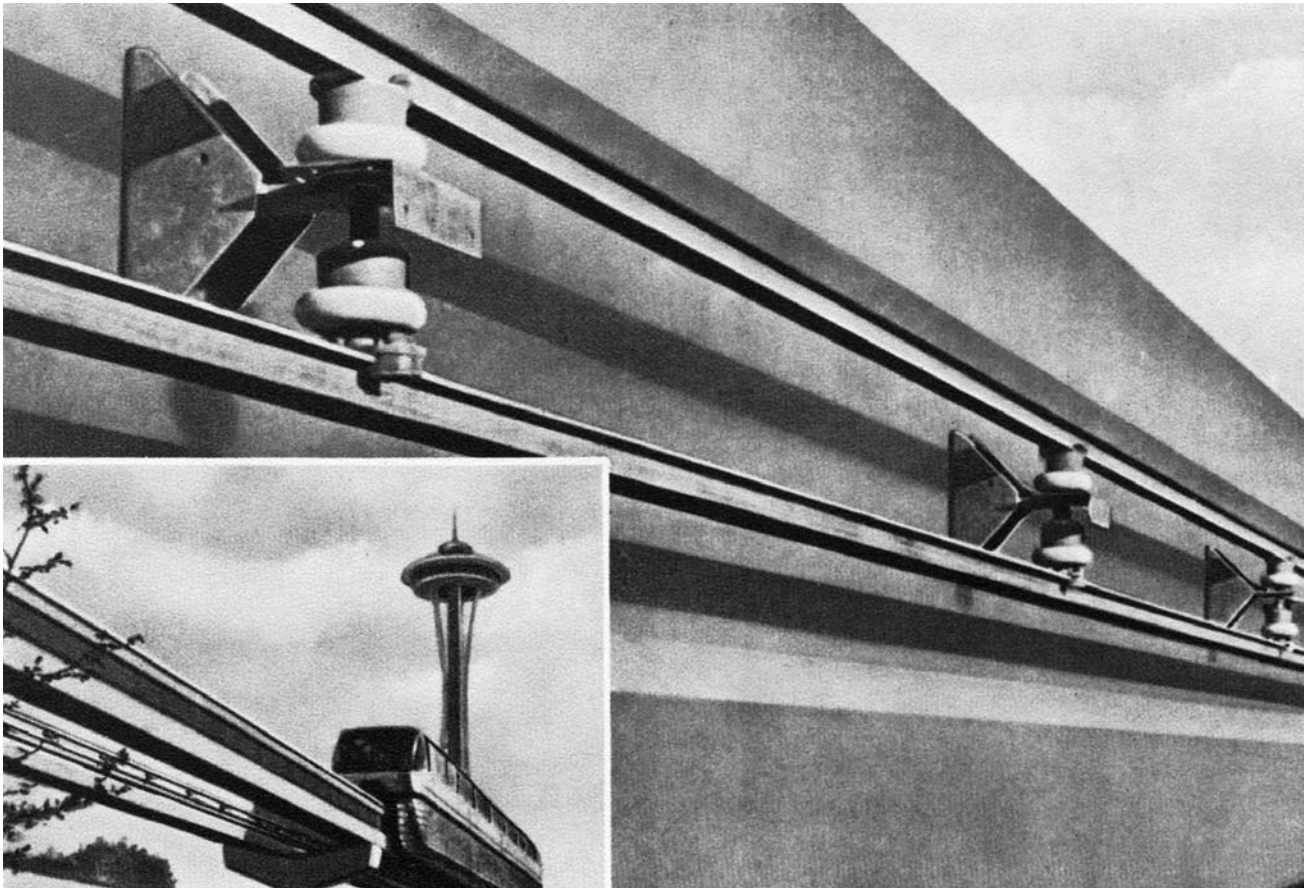
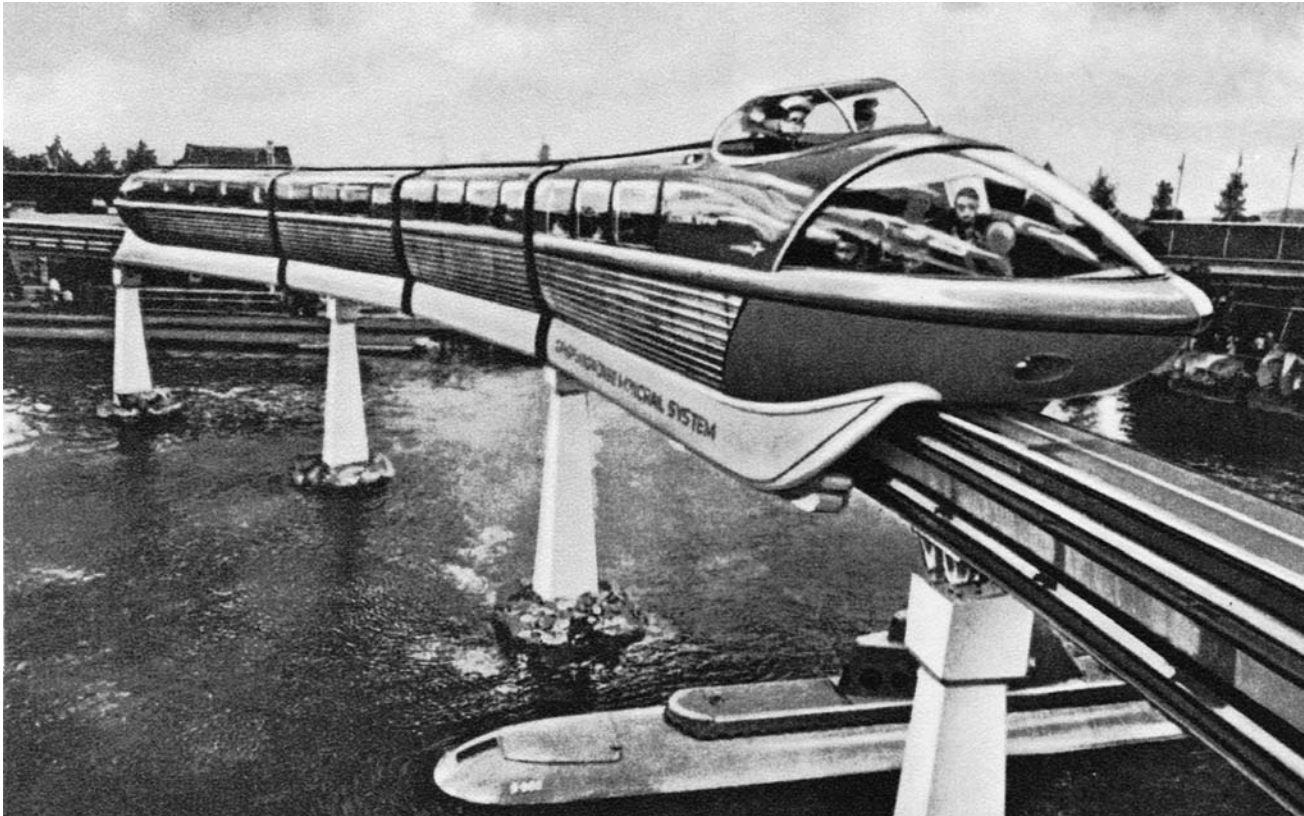





DQS certified in accordance with DIN EN ISO 9001:2000  
OHSAS 18001 (Reg. no. 003140 QM OH)

Catalog No.

Copperhead Conductor Systems	1 a
Battery Charging Systems	1 b
Insulated Conductor Systems U 10	2 a
Insulated Conductor Systems U 20 – U 30 – U 40	2 b
Insulated Conductor Systems U 15 – U 25 – U 35	2 c
Aluminium Enclosed Conductor Systems LSV – LSVG	3 a
Powerail Enclosed Conductor Systems KBSL – KSL – KSLT	4 a
Powerail Enclosed Conductor Systems VKS – VKL	4 b
Powerail Enclosed Conductor Systems MKLD – MKLF – MKLS	4 c
Powerail Enclosed Conductor System VKS 10	4 d
Powerail Enclosed Conductor System KBH	4 e
Heavy Enclosed Conductor Systems	5
Trolley Wire and Accessories	6
Cable Tenders	7
Cable Carriers for □-tracks	8 a
Cable Carriers for Flatarm Cable on I-beams	8 bF
Cable Carriers for Round Cable on I-beams	8 bR
Cable Carriers for ◇-tracks	8 c
Conductor Cables and Fittings	8 L
Spring Operated Cable Reels	9 a
VAHLE POWERCOM® – Data Transmission Systems	9 c
CPS® – Contactless Power Supply	9 d
SMG – Slotted Microwave Guide	9 e
WCS – Position Encoding System	9 f
Motor Powered Cable Reels	10